

1		2		3		4		5		6			
Document No.	QR4-700-T-003	REV.	A/0	REV.	0	DESCRIPTION	-	REVISOR	mw.Yang	DATE	08.23.2024	APPROVED	Y.Yang

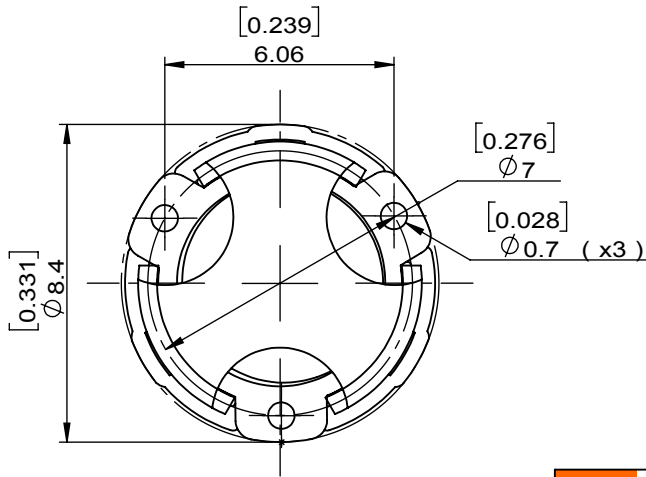

SPECIFICATIONS	
Part's Number	JCM2300T2400LM2-CY
Frequency(GHz)	2.300~2.400
Direction	CW
Insertion Loss(dB)MAX	0.35@25°C 0.40@-40~+85°C
Isolation(dB)MIN	20.0@25°C 18.0@-40~+85°C
Return Loss(dB)MIN	20.0@25°C 18.0@-40~+85°C
3rd IMD(dBc)MAX	-
Power FWD/REV/PK(Watt)	20/20/100
Operating Temperature(°C)	-40~+85
Storage Temperature(°C)	-
2nd/3rd Harmonic(dBc)	-
Termination/Attenuator(Watt/dB)	-
Tab(W×LG×THK)(mm[Inch])	-
Additional Notes	-

<b>JQL</b> JQL Technologies Corporation				
<b>MATERIAL:</b> STEEL		<b>DWG NO:</b> JCM2300T2400LM2-CY		
<b>SURFACE TREATMENT:</b> SILVER PLATING		DWG BY:	mw.Yang	08.23.2024
<b>DESCRIPTION:</b> SMT CIRCULATOR		CHK'D BY:		SCALE
		APP'V'D BY:		5:1
		Unit: mm[inch]	Tolerance: Liner: ±0.25 Anguar: ±0.5°	The First: 
				A4

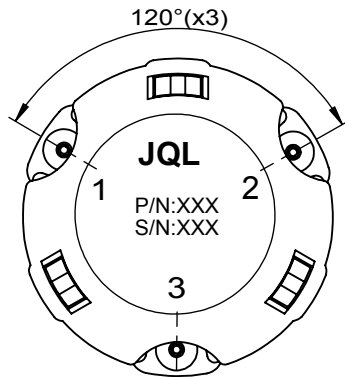
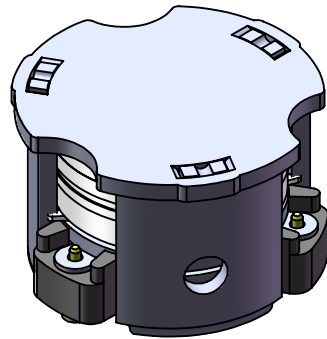
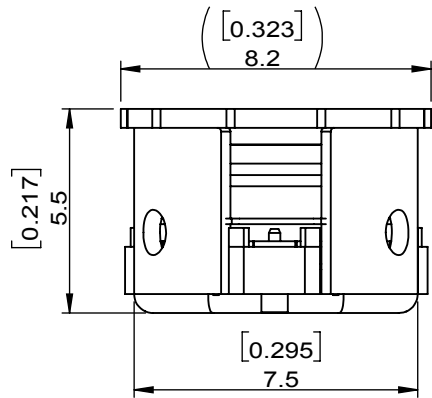

This document is the property of JQL Technologies Corporation. It cannot be copied, duplicated, used for manufacturing purposes or communicated to third party as a whole or partly, without the written consent of JQL Technologies Corporation.